



COMMERCIAL FOOD PROCESSOR

- Design for vertical cutting and mixing
- Lid has sealed to prevent leaking
- New “latch” locking device on continuous feed assembly and bowl assembly
- Hinged large feed pusher assembly with safety stop
- Two deep feed openings
- Attachments easily removed for assured sanitation
- Easy to read speed control guide



HL-P60



HL-P35

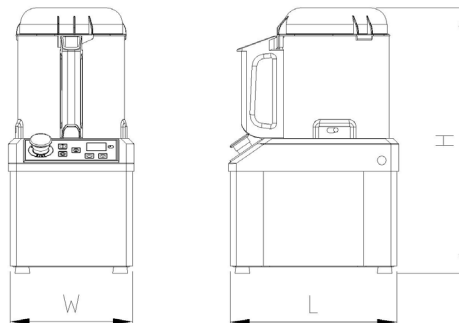

Specifications :

Model No.	Bowl Capacity	Motor	Agitator Speed (RPM)	Voltage	Dimensions L * W * H (mm)	N.W. (KG)
HL-P35	3.5 Qt	1/2HP / 0.375Kw	1450 -3500	110V/220V	300*200*478	15
HL-P60	6 Qt	1HP / 0.75Kw			384*300*518	35
HL-P80	8 Qt	1.2HP / 0.9Kw			384*330*578	36
HL-P100	10 Qt	1.5HP / 1.25Kw			384*330*638	38

HSIAO LIN MACHINE CO., LTD.
 NO. 68, ALLEY 53, LANE 960. FENG
 CHOU RD., SENG KANG DISTRICT,
 TAICHUNG CITY, TAIWAN 429



TEL : +886-4-25610858

FAX : +886-4-25626266

http : //www.dynastymixer.com

E-mail : service@hlm.com.tw

食物調理機

- * Design for vertical cutting and mixing
- * Lid has sealed to prevent leaking
- * New “latch” locking device on continuous feed assembly and bowl assembly
- * Hinged large feed pusher assembly with safety stop
- * Two deep feed openings
- * Attachments easily removed for assured sanitation
- * Easy to read speed control guide

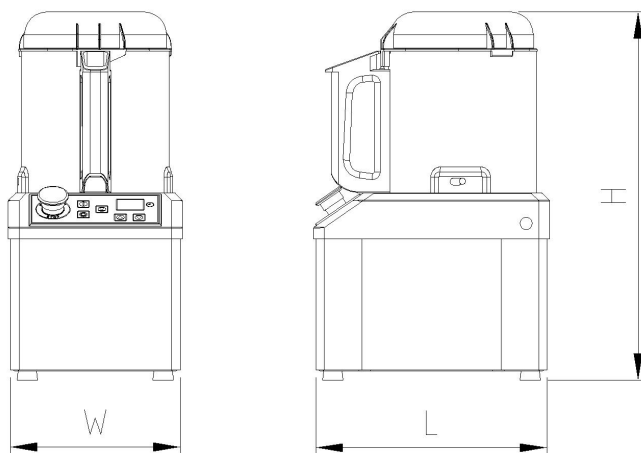

Specifications :

型號	桶容量	馬力	工具轉速 (RPM)	電壓 V/HZ/PH	機器尺寸 長*寬*高(mm)	淨重
HL-P35	3.5 公升	1/2HP 0.375Kw	1450 (50HZ) 1720 (60HZ)	220/50/1 220/60/1	300*200*478	28Kg
HL-P60	6 公升	1HP 0.75Kw			384*300*518	35Kg
HL-P80	8 公升	1.2HP 0.9Kw			384*330*578	36Kg
HL-P100	10 公升	1.5HP 1.25Kw			384*330*638	38Kg